

RAXX

PRODUCT MANUAL





©1998 - 2024 BOXX Technologies
Printed in the United States of America
4616 W Howard Ln, Suite 105
Austin, TX 78728
1.877.877.BOXX | 512.835.0400
www.bbox.com

BOXX® Technologies, BOXX®, APEXX®, RAXX®, GoBOXX, renderPRO, and renderBOXX® are registered trademarks of BOXX Technologies, registered in the U.S. Patent and Trademark Office. Other product and company names herein may be trademarks or registered trademarks of their respective owners. This document is intended for development purposes and is the sole property of BOXX Technologies. Unauthorized reproduction is strictly prohibited where applicable by law. ©1998 - 2024 BOXX Technologies

TABLE OF CONTENTS

3	CONGRATULATIONS ON YOUR PURCHASE Included in this Guide
4	IMPORTANT INFORMATION Owner/System Administrator Tasks
5	SAFETY Setting up Your Equipment Using Your Equipment Performing Maintenance
8	QUICK SETUP Windows® GML/COA location
9	PASSWORDS
10	SYSTEM DIAGRAMS
14	INTERNAL ACCESS
28	RACKMOUNT INSTRUCTIONS
38	HOW TO OBTAIN TECHNICAL SUPPORT
39	ABOUT BOXX TECHNOLOGIES
40	WARRANTY INFORMATION Warranty Supersession General Information Limited Warranty Terms Third-Party Peripherals Third-Party Software Limited Warranty Coverage: Year One Limited Warranty Coverage: Years Two and Three BOXX Exchange Policy BOXX Exchanges and Advanced Replacement General Provisions Premium Support Hardware Warranty What to do When You Have a Service Issue 24 x 7 Services
50	NOTES

CONGRATULATIONS ON YOUR PURCHASE

Congratulations and thank you for your purchase! BOXX Technologies is proud to have your support, and we look forward to working with you in the future. Please read this guide in full and follow its instructions as detailed.

INCLUDED IN THIS GUIDE

This document describes information pertinent to owning and configuring your BOXX Technologies system. This is also your reference for warranty, support and service-related questions. This guide is intended for owners, system administrators, and users of BOXX Technologies systems and is written with the assumption that the reader has a basic working knowledge of computer operations.

RAXX | Boxx Technologies
FOR HOME OR OFFICE USE



Assembled From
Tested Components
(Complete System Not Tested)

IMPORTANT INFORMATION

OWNER/SYSTEM ADMINISTRATOR TASKS

Your BOXX Technologies system includes a 3-year parts replacement warranty and is considered customer-installable. BOXX Technical Support may be contacted to assist with the setup and configuration of your system. The following tasks are expected to be performed by the system owner/system administrator:

- ▶ Setup and connectivity of all peripherals in the system.
- ▶ Configuration of applications and the operating system.
- ▶ Administration of software applications and the operating system.
- ▶ Removal and installation of system components (e.g., disk drives, power supplies, DIMMs, etc.) if component failure should occur.
- ▶ Installation and system integration of system upgrades such as memory, operating system and storage.

Every user should review the following safety information prior to setting up equipment. This information should be followed to prevent damage to your equipment, personal injury, or death. Please follow the guidelines below.

SETTING UP YOUR EQUIPMENT

Note the following safety guidelines:

- ▶ Assemble your equipment in a clean area with ample space to unpack and assemble it completely.
- ▶ Equipment may weigh in excess of 40 pounds. Use caution when lifting or moving equipment. Consider having an assistant help you.
- ▶ Lift heavy objects with your legs bent while keeping your back straight.
- ▶ Never assemble or work on your equipment with the power cord connected. Always remove the power cord from both the wall outlet and the back of your equipment when assembling, servicing, installing or removing hardware.
- ▶ Wear electrostatic wrist-bands or other electrostatic protection when servicing your equipment to prevent damage to the electrical components.



Caution, risk of electric shock



No user servicable parts
Aucune pièce réparable par l'utilisateur



Caution, Hot Surface

USING YOUR EQUIPMENT

Note the following safety guidelines:

- ▶ Never operate your equipment with panels or covers removed.
- ▶ Make sure the voltage selection switch on your power supply matches your AC power source:

115 volts (V)/60 Hertz (Hz) in most of North America, South America, and some Far Eastern countries such as Japan, South Korea, and Taiwan.

230V/50Hz in most of Europe, the Middle East, and the Far East.

- ▶ Use properly grounded power cords with three-pronged outlets to supply power to your equipment and peripherals.
- ▶ For pluggable equipment, the socket-outlet must be installed near the equipment and shall be easily accessible.
- ▶ Protect your equipment from power surges with surge protectors or Uninterrupted Power Supplies (UPS).
- ▶ Do not use liquids around your equipment.
- ▶ Place your equipment in a well-ventilated area where the vents are free from obstruction.
- ▶ Disconnect the power cable before removing protective panels, performing hardware maintenance, installing hardware, or configuring hardware components.
- ▶ Using the product power switch does not guarantee that power is off or that power is not supplied to the product.
- ▶ The owner accepts all liability when operating, setting up, or configuring the product described within this manual.

PERFORMING MAINTENANCE

Preventative and scheduled maintenance can extend the life of your equipment. However, performing maintenance can also create hazardous conditions for you and your equipment.

Note the following safety guidelines when performing maintenance:

- ▶ Always unplug the power cord from the wall outlet and the back of your equipment before maintenance begins.
- ▶ Wait 5 minutes after removing power from the system, allowing components to cool before performing any hardware installation/removal.
- ▶ In order to prevent electrostatic damage, properly ground yourself before performing system maintenance.
- ▶ Always touch the equipment housing before touching any electronic components.
- ▶ Handle components and cards with care, remembering not to touch the exposed contacts.
- ▶ Turning the system power switch off does not guarantee that power is not being supplied to the product.
- ▶ Disconnect the power cable before removing protective panels, performing hardware maintenance, installing hardware, or configuring hardware components.

QUICK SETUP

WINDOWS® GML/COA LOCATION

This quick setup guide describes the steps involved in unpacking a system, attaching peripherals, and loading the operating system.

- 1 Save all of the packing materials when unpacking the shipping box. If the system is ever returned for service and is damaged in transit due to improper packaging, the warranty may be voided.
- 2 If the system was ordered with Microsoft® Windows®, locate and record the Product Key listed on the operating system's sticker located either behind the removable front grill or in the rear of the chassis. Please record the key below for your records:

- Note: Windows® now comes with a digital product key. The license information is stored in the system BIOS, and a Genuine Microsoft Label (GML) is located on the chassis instead of the traditional COA sticker.*

- 3 Attach all computer peripherals.
- 4 To power up the system, press the black power button on the front of the system.
- 5 Complete the following step based on which operating system is installed:

For Windows® products, there is no account or password set by default. This is established during the initial setup of the operating system on the first boot. If an account is set up prior to the system leaving the factory, the account and password information is as follows:

Username: boxx
Password: boxx-<serial no.>
(ex. boxx-B123456)

- 6 Configure the server's network settings according to the appropriate local network specifications.

*More information and examples of Genuine Microsoft Labels and COA stickers can be found at:

<https://www.microsoft.com/en-us/howtotell/hardware-pc-purchase>

DEFAULT PASSWORDS

BOXX Technologies hardware is in compliance with California Law SB-327 Information privacy: connected devices. This section will define the BOXX Technologies password system requirements for unique access.

RAXX 1U
SYSTEM DIAGRAM

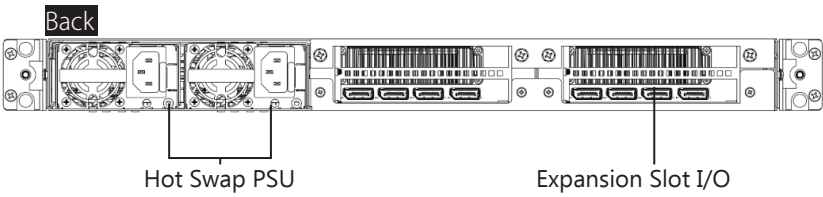
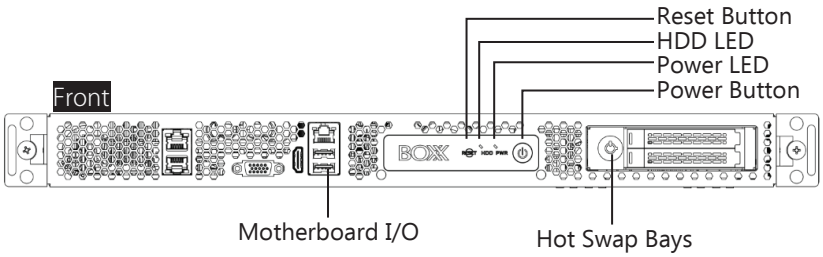

RAXX 2U SYSTEM DIAGRAM

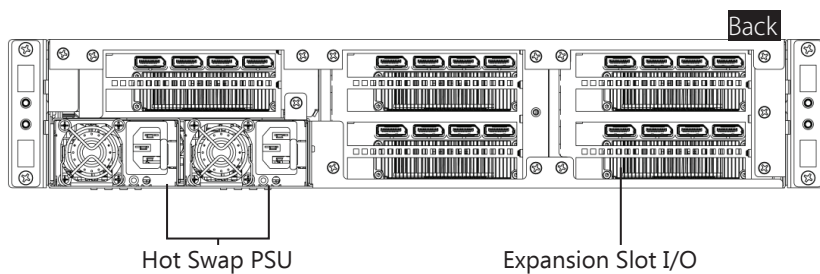
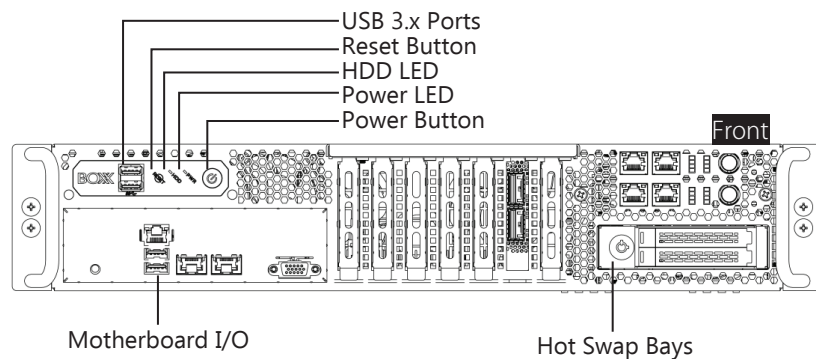

RAXX 3U
SYSTEM DIAGRAM

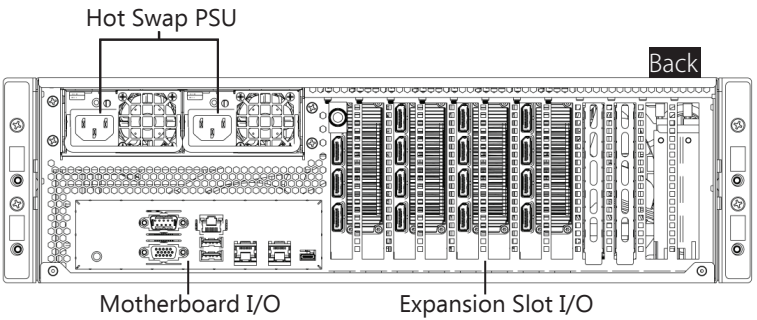
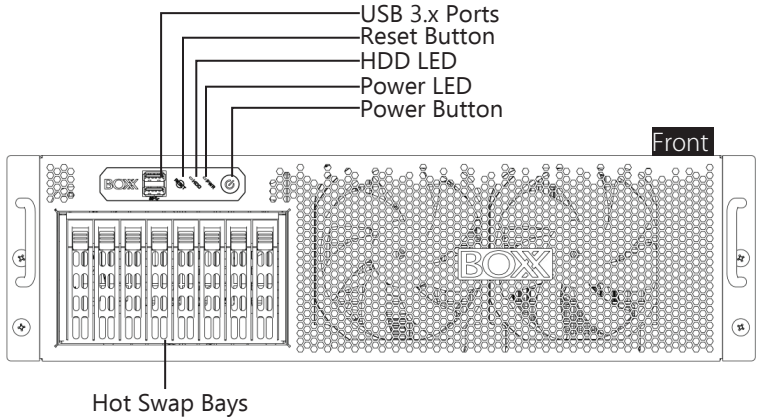



RAXX 1U - Authorized Technicians
INTERNAL ACCESS

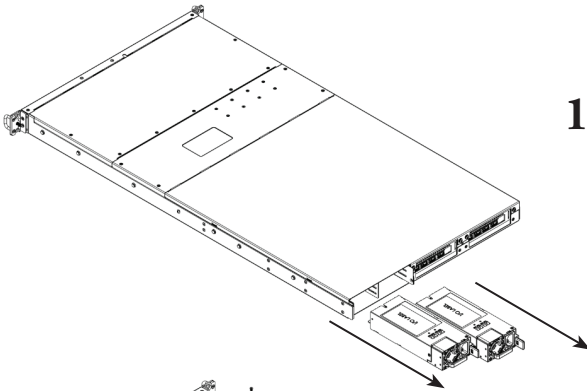

1 Push release lever and pull to remove power supplies (2).

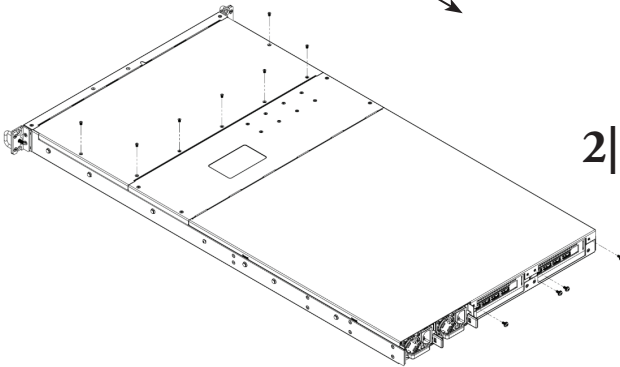

2 Remove lid screws (11).

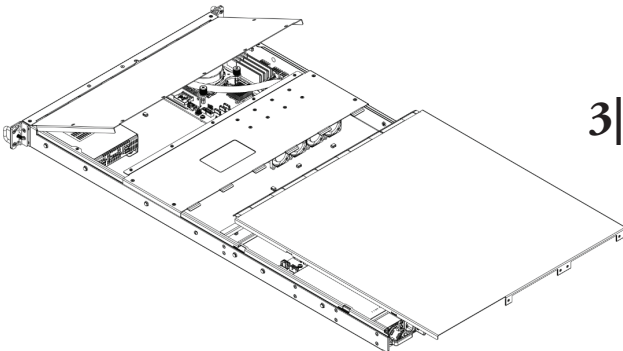

3 Remove lid.

- 4 | Remove screws (13)
Lift drives.

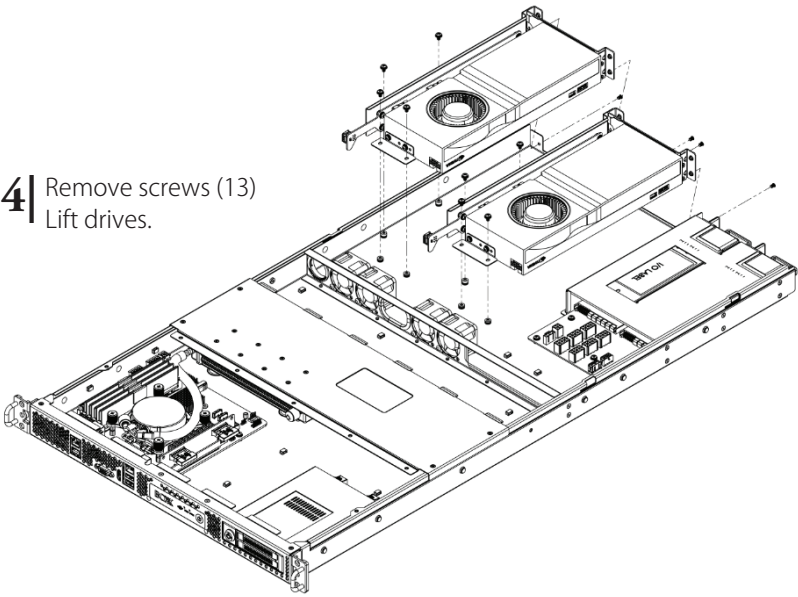

- 4 | Alternate view

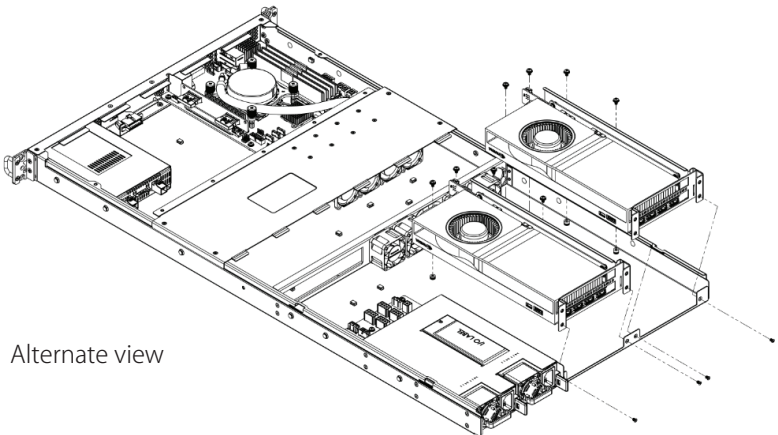

RAXX 1U - Authorized Technicians
INTERNAL ACCESS

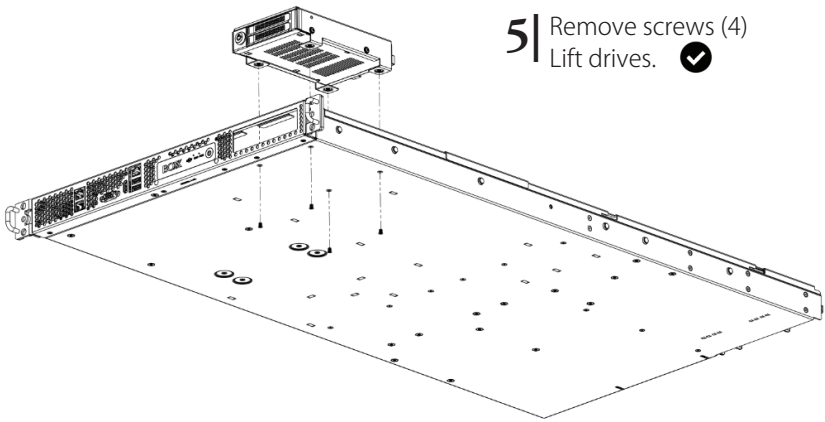

5 | Remove screws (4)
Lift drives. ✓



RAXX 2U - Authorized Technicians

INTERNAL ACCESS

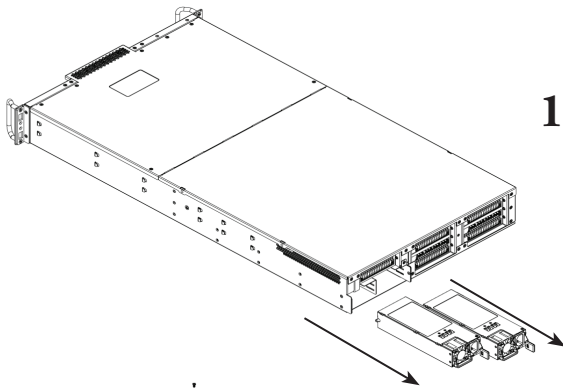

1 Push release lever and pull to remove power supplies (2).

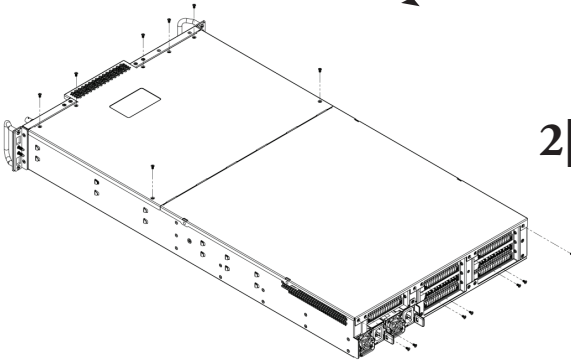

2 Remove lid screws (14).

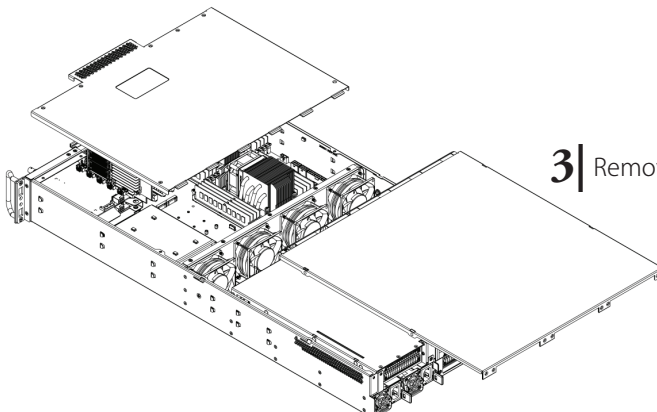

3 Remove lid.

RAXX 2U - Authorized Technicians INTERNAL ACCESS

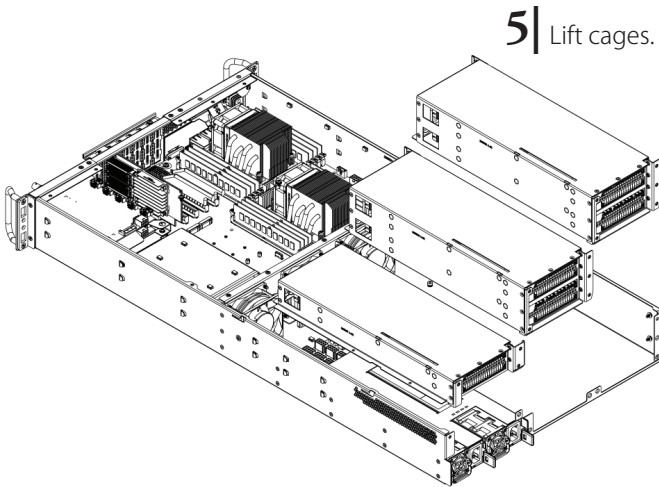
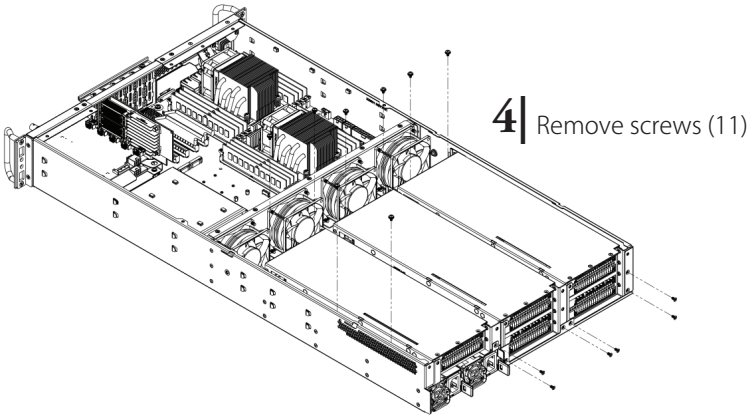

RAXX 2U - Authorized Technicians

INTERNAL ACCESS

- 6 | Remove screws (5).
Remove GPU. ✓

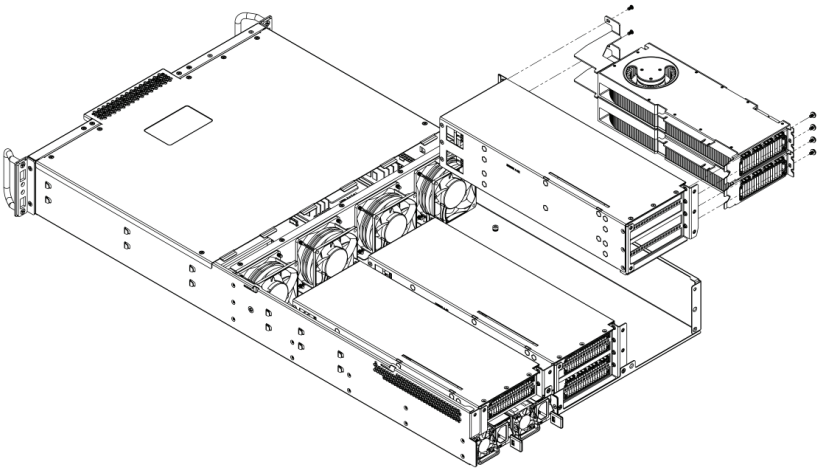

Some models require removal of the expansion slot shroud for full memory slot access. See page 21

For illustrative purposes only. Some details vary by model and configuration.



RAXX 3U- Authorized Technicians
INTERNAL ACCESS

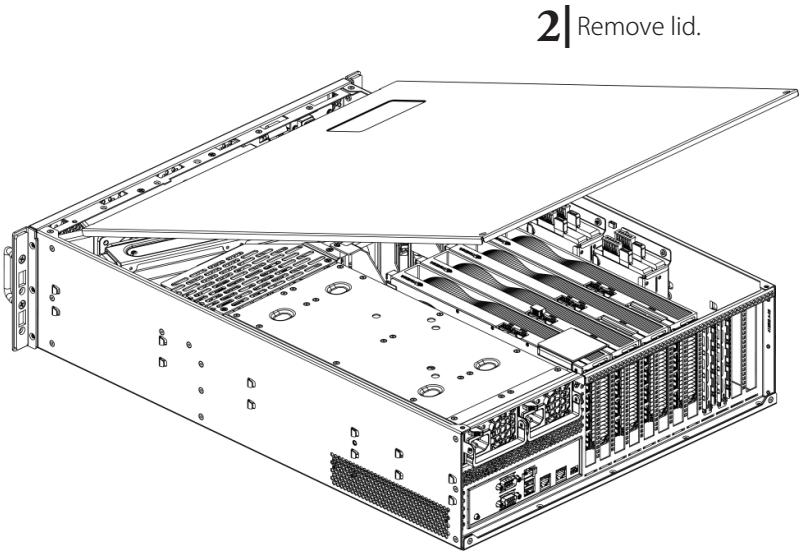
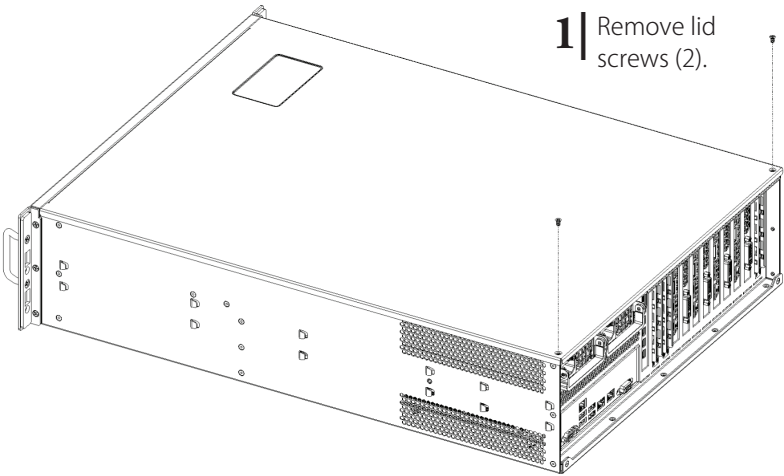

RAXX 3U- Authorized Technicians
INTERNAL ACCESS

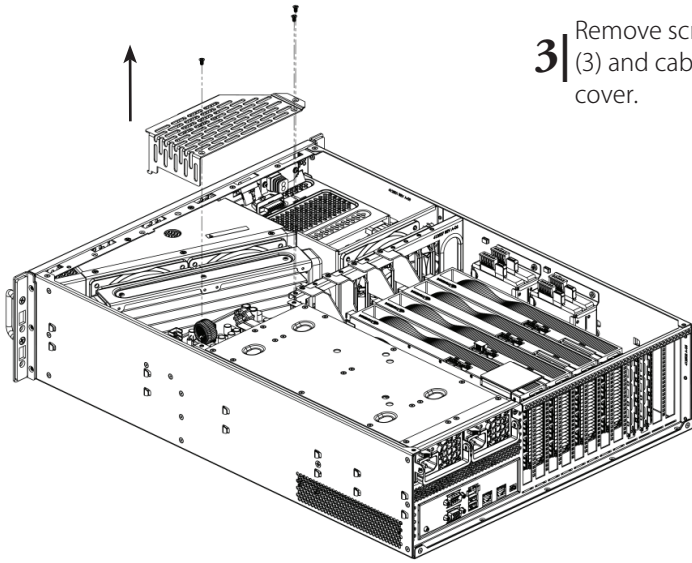

3 Remove screws (3) and cable cover.

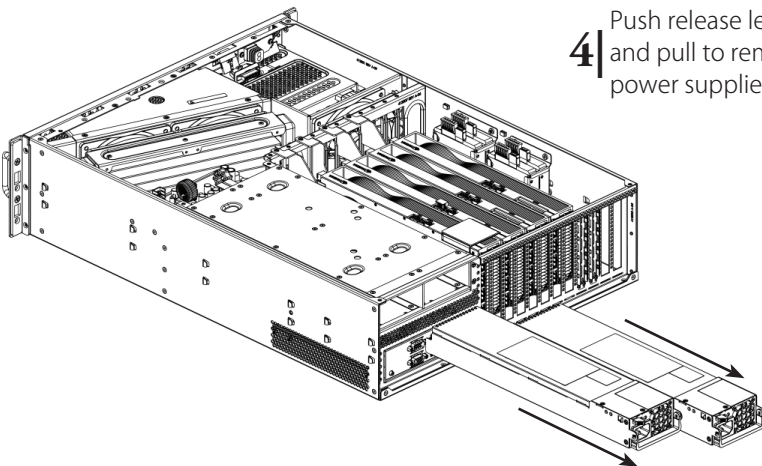

4 Push release lever and pull to remove power supplies (2).

RAXX 3U- Authorized Technicians
INTERNAL ACCESS

5 | Remove screws (6) and lift power supply bay. ✓

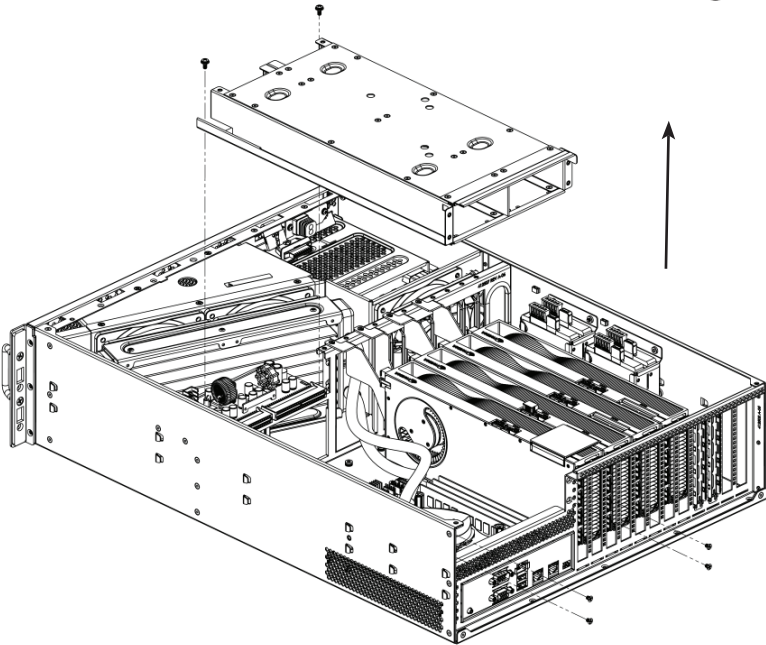

RAXX 1U- Authorized Technicians
INTERNAL VIEW

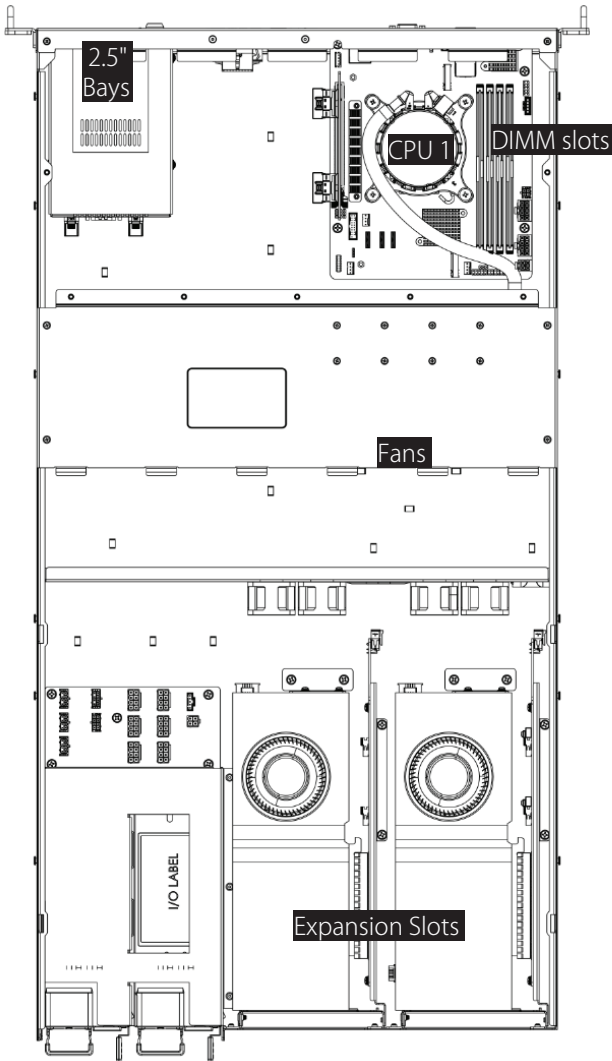

RAXX 2U- Authorized Technicians
INTERNAL VIEW

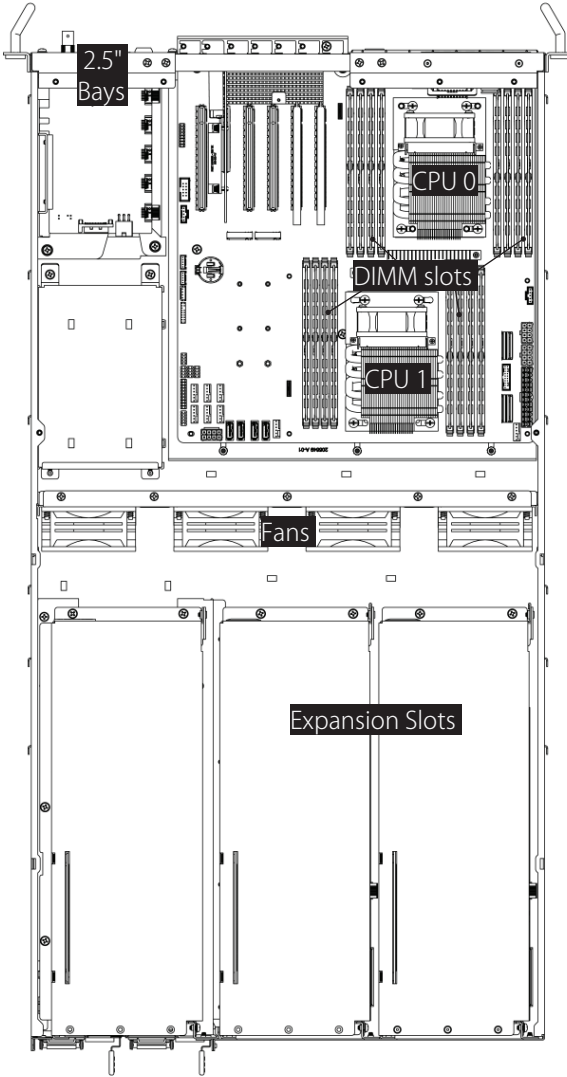

RAXX 3U - Authorized Technicians
INTERNAL VIEW

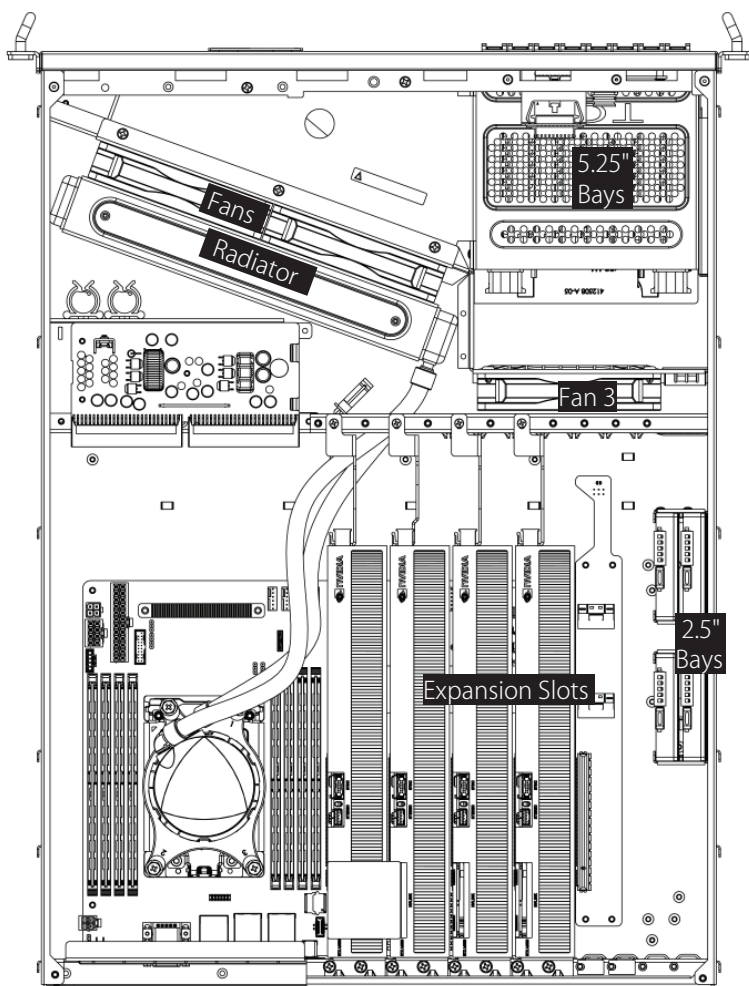



To prevent bodily injury when mounting or servicing this unit in a rack, the following guidelines must be adhered to:

- ▶ Do not pick up the chassis using the front handles. The handles are only designed to pull the system out of the rack once it is installed.
- ▶ This chassis should be mounted at the bottom of the rack if it is the only unit in the rack.
- ▶ When mounting this chassis in a partially filled rack, load the rack from the bottom to the top with the heaviest component at the bottom of the rack.
- ▶ If the rack is a standalone unit, it should be bolted to the floor or anti-tip stabilizing devices should be installed.
- ▶ If the rack is part of a gang, gang attachment devices must be installed.
- ▶ Do not install this chassis into a two post "telco" style rack.
- ▶ This chassis is NOT to be used as a shelf or a work space in either an extended or retracted position.

Long Slide Rail Kit BOXX part number 11021 – fits racks 26.5" to 36.4" deep
Short Slide Rail Kit BOXX part number 11022 – fits racks 19" to 26.6" deep

RAXX 2U/3U- Authorized Technicians
RACKMOUNT INSTRUCTIONS



A1

Pull the inner rail and middle rail out of the outer rail until it is fully extended.

**Slide Rail Assembly
(Left Hand)**

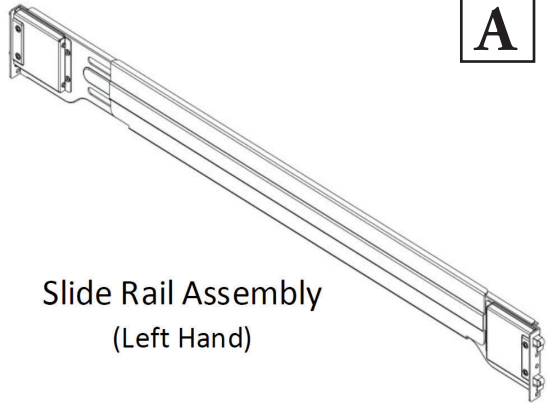

A2

Depress the inner rail locking tab to release the inner rail.

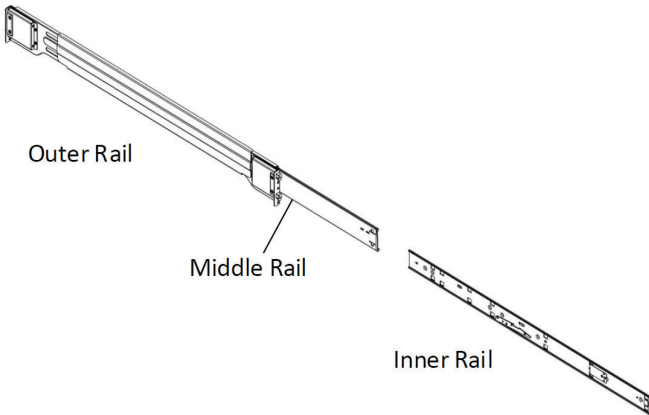
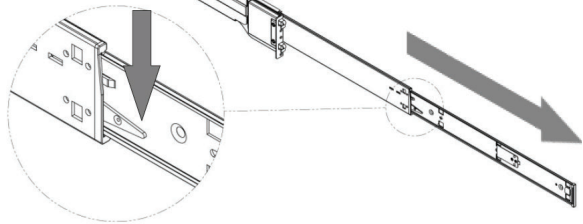

Note: These slide rails are designed for use on 19" racks with 3/8" square holes.

For 19" racks with round non-threaded holes, use Adapter Kit BOXX part number 10936.

For 19" racks with threaded holes, use Adapter Kit BOXX part number 11009

Using Adapter Kit Increases all rack depth values by ~1.6"

RAXX 2U/3U- Authorized Technicians

RACKMOUNT INSTRUCTIONS

B

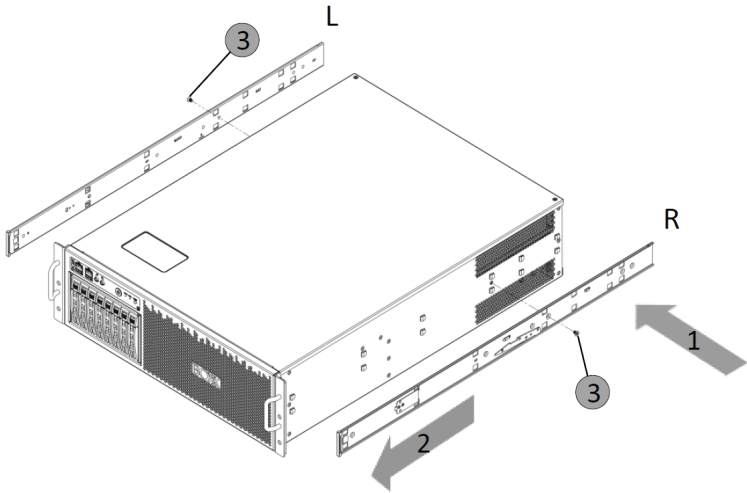

- B1 Place the inner rail firmly against the side of the chassis with the hooks on the chassis passing through the rectangular holes of the inner rail.
- B2 Slide the inner rail forward under the hooks until it clicks into locked position.
- B3 Install the M4 x 6 flat head screws to secure the inner rails to the chassis.

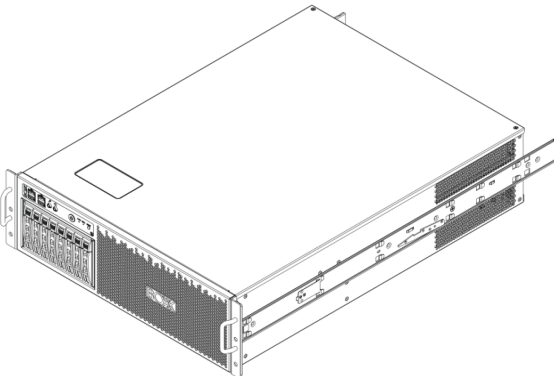

C

Press the middle rail locking
tab and push the middle rail
back into the outer rail.

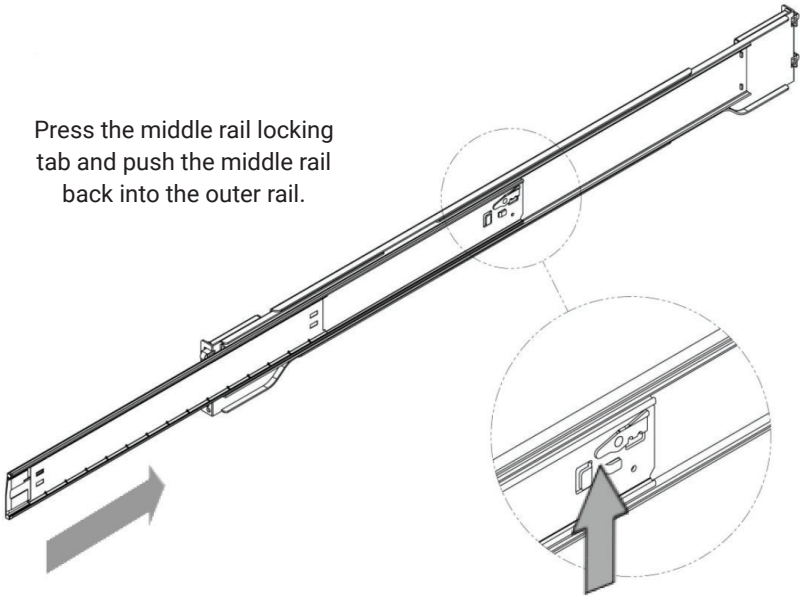

In Step D, be certain that you use the same rackmount holes on all four vertical posts to ensure proper alignment of the slide rails, front-to-back and left-to-right.

RAXX 2U/3U- Authorized Technicians
RACKMOUNT INSTRUCTIONS

D

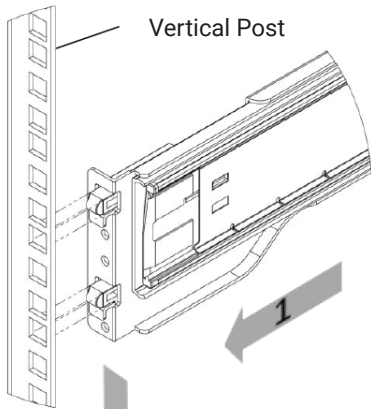

Hang the hooks of the left hand outer rail on the square holes in the vertical post in the desired location.

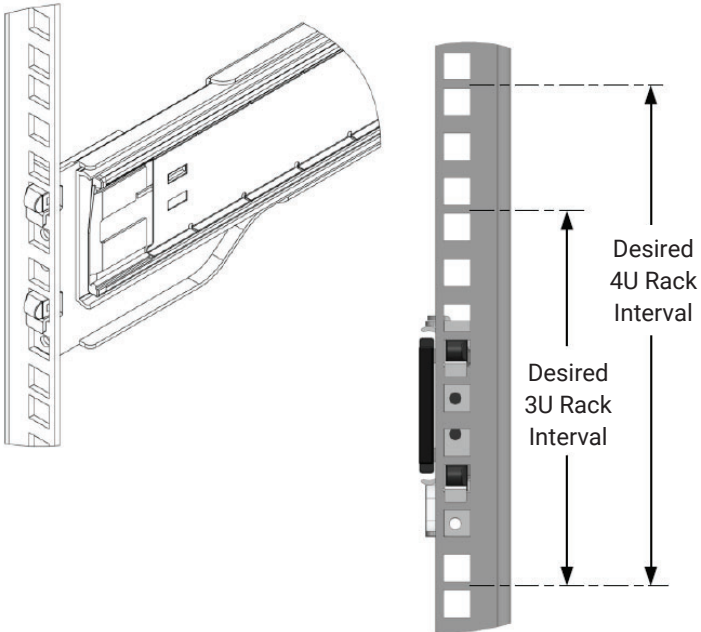

In Step E, be certain that you use the same rackmount holes on all four vertical posts to ensure proper alignment of the slide rails, front-to-back and left-to-right.

RAXX 2U/3U- Authorized Technicians RACKMOUNT INSTRUCTIONS

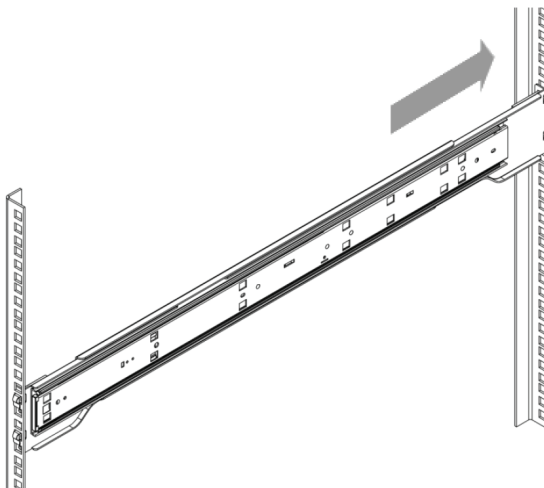

- E1 Extend rear bracket from the outer rail and repeat Step D to attach it to the rear post.
- E2 Repeat Steps C, D, and E to mount the right hand slide rail.

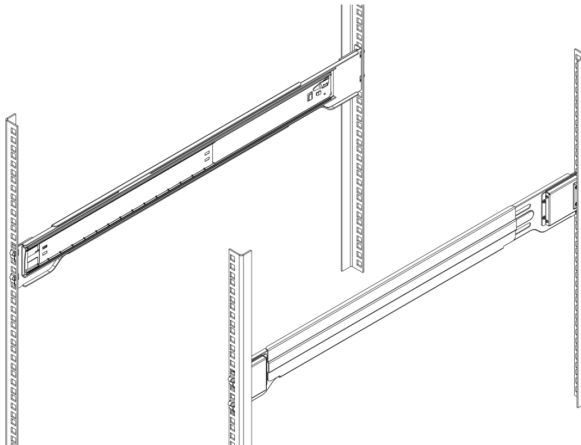

F

F1

Pull the middle rails out of the front outer rails into their locked positions, and make sure that the ball bearing shuttles are located at the front of the middle rails.

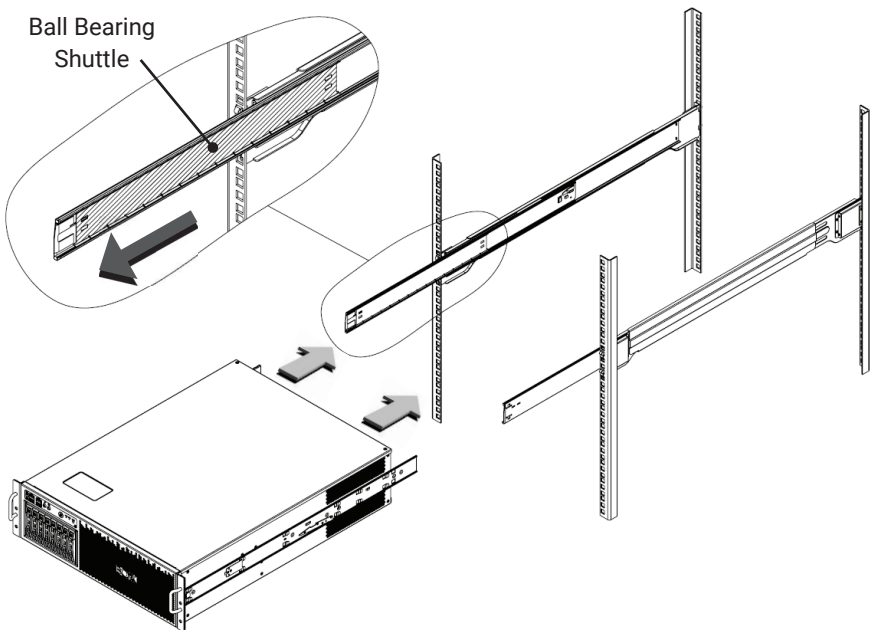

F2

Align and engage the inner rails with the middle rails and then push evenly on both sides of the chassis until it clicks into the fully extended position.

RAXX 2U/3U- Authorized Technicians
RACKMOUNT INSTRUCTIONS

F

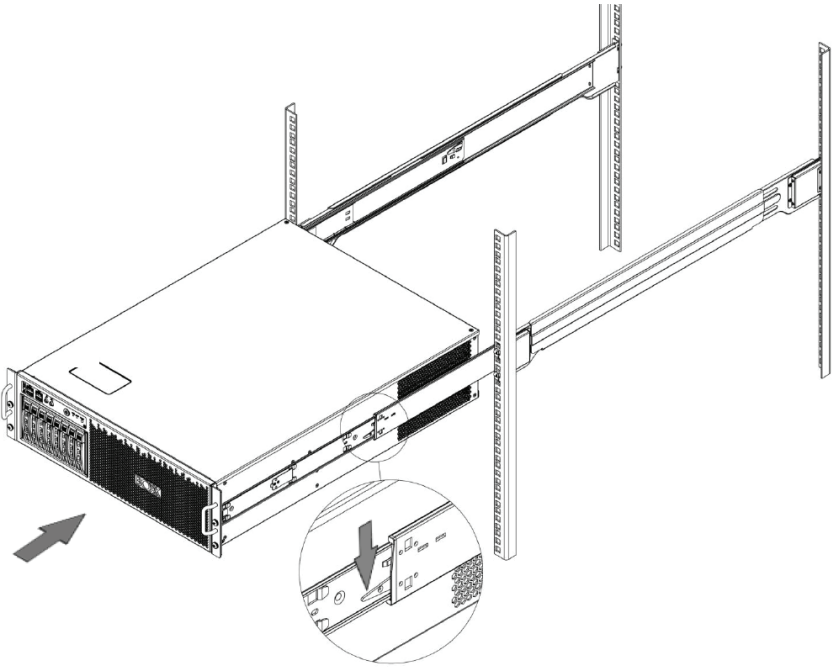

F3

Simultaneously depress the inner rail locking tabs on both sides of the chassis and push the chassis all the way into the rack until the handle flanges make contact with the front of the vertical posts.

RAXX 2U/3U- Authorized Technicians
RACKMOUNT INSTRUCTIONS

G

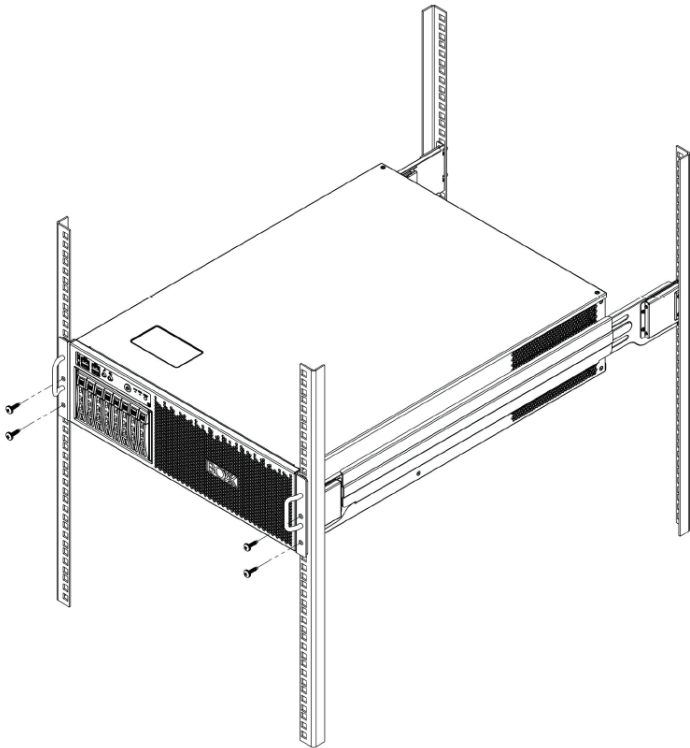

Install the four black #10-32 truss head screws to secure the handle flanges to the rack. ✓



HOW TO OBTAIN TECHNICAL SUPPORT

LEGENDARY BOXX TECHNICAL SUPPORT

For technical assistance, please call or e-mail BOXX Technical Support. If you experience a problem with your BOXX system, please contact us immediately and we will remedy the situation. Please have your system serial number available when requesting service.



Email: support@boxx.com
Phone (Toll Free): 1-877-877-BOXX (2699)
Phone: 512-835-0400 (Outside North America)
7 a.m.–6 p.m.
CST Monday–Friday

ONLINE

Detailed information regarding the full portfolio of BOXX Technologies solutions is available online at www.boxx.com.

ABOUT BOXX TECHNOLOGIES

BOXX is committed to providing affordable, technically-advanced systems that deliver outstanding performance and customer satisfaction. BOXX systems are optimized for high performance and the company's high customer satisfaction rate is credited to its solid system technology, comprehensive system warranties, and knowledgeable technical support staff. BOXX's Technical Support Staff is Microsoft® and Intel® certified with extensive knowledge of Linux and Microsoft® Enterprise for support of various system configurations.

BOXX MANUFACTURES HARDWARE FOR



DATA SCIENCE



MEDIA & ENTERTAINMENT



GOVERNMENT, EDUCATION, & MEDICINE



MANUFACTURING & PRODUCT DESIGN



ARCHITECTURE, ENGINEERING, & CONSTRUCTION

WARRANTY INFORMATION

WARRANTY SUPERSESSION

This warranty offer expressly supersedes any conflicting warranty terms listed in purchase orders, verbal agreements, or other warranty information set forth by BOXX Technologies, (BOXX). This warranty constitutes an offer or counter-offer subject only to the terms and conditions set forth herein. In addition, this warranty is conditional upon the buyer's agreement to the terms and conditions described within this warranty whether in writing or by conduct. Conduct includes product retention, use, acceptance of, or payment for BOXX products or services and constitutes acceptance through conduct. If this warranty is not acceptable to the buyer, the buyer should contact their BOXX sales representative immediately.

GENERAL INFORMATION

BOXX offers Buyers of the APEXX, renderPRO, and renderBOXX a three-year limited warranty and Buyers of the GoBOXX Series Mobile Workstation a one-year limited warranty, each as described and limited in this Agreement. The term "Buyer" includes individuals, businesses, third-party vendors, or organizations that render payment for any Product. This limited warranty offered by this Agreement extends only to Buyer and is not transferable to anyone who subsequently purchases, leases or otherwise obtains Product from Buyer. This limited warranty does not cover software or non-BOXX branded products. During year one, this limited warranty covers parts, Operating System telephone support, and return shipment costs. During years two and three, this limited warranty covers parts and Operating System telephone support only. Buyer assumes shipment costs during years two and three. (BOXX offers service contracts for additional technical support and support services. Buyer should contact its BOXX sales representative for service contract information and terms.) However, this limited warranty does not include products manufactured by third-party vendors. Thus, this limited warranty does not cover third-party peripherals offered with BOXX Products. In the event of a third-party peripheral failure, Buyer should contact the third-party peripheral manufacturer for warranty redemption. Please see the third-party warranty information supplied with Buyer's order for more information.

LIMITED WARRANTY TERMS

This limited warranty does not cover and BOXX is not responsible for, including but not limited to, the following: a) delivery or installation, or labor charges for installation or setup of the Product, adjustment of customer controls on the Product, and installation or repair of antenna systems outside of the Product; b) damages caused by misuse, abuse, accidents, fire, theft, natural disasters, disappearance, misplacement, fluctuations and power surges, connections to improper voltage or incorrect electrical line voltage, viruses, malware, reckless, willful, or intentional conduct; c) damages caused by servicing not authorized by BOXX; d) damages caused by usage that is not in accordance with Product instructions or user manuals; e) damages caused by failure to follow the Product instructions or user manuals or failure to perform cleaning or preventive maintenance; f) damages caused by the combination of BOXX branded Products with other non-BOXX branded products, accessories, parts or components or use of products, equipment, systems, utilities, services, parts supplies, accessories, applications, installations, repairs, external wiring or connectors not supplied or authorized by BOXX which damage the Product or result in service problems; g) uninterrupted or error-free operation of the Product; h) software, including the operating system and software added to Product through our factory-integration system, third-party software, or the reloading of software; i) any equipment or components that were not included in Product as originally sold to Buyer; j) normal wear and tear; k) minor imperfections that meet design specifications; l) cosmetic damage or exterior finish that does not affect functionality; m) Products where the BOXX serial number is missing, altered or defaced; n) external speakers, keyboards and mice; o) damage caused as a result of improper transportation or packing/packaging when returning the Product to BOXX or a BOXX authorized service provider; p) a Product that requires modification or adaptation to enable it to operate in any country other than the country for which it was designed, manufactured, approved and/or authorized, or repair of Products damaged by these modifications.

WARRANTY INFORMATION

THIRD PARTY PERIPHERALS

As stated previously, this limited warranty does not cover third-party peripherals manufactured by third-party vendors. These peripherals include, but are not limited by, the following categories.

- ▶ Third-party peripheral devices such as monitors, keyboards, mice, and speakers
- ▶ Third-party peripherals added to a BOXX Product by Buyer
- ▶ Third-party peripherals added to a BOXX Product by any party other than an authorized BOXX representative

While BOXX may supply third-party peripherals with BOXX Products, Buyer should consult the third-party peripheral manufacturer for warranty claims related to third-party peripherals. Consult the third-party peripheral manufacturer's warranty information supplied with Buyer's order for more information.

THIRD PARTY SOFTWARE

Similar to the provisions of the third-party peripherals, this limited warranty does not cover third-party software. While this limited warranty covers software designed and implemented by BOXX, it does not cover problems resulting from third-party software installed by either BOXX or Buyer. Buyer should consult the BOXX website for more information related to BOXX Products and third-party software conflicts prior to submitting warranty claims with third-party software manufacturers. In all other circumstances, Buyer should forward warranty claims related to third-party software to the appropriate software manufacturer.

LIMITED WARRANTY COVERAGE YEAR ONE

As stated previously, warranty coverage becomes effective on the invoice date. BOXX will repair or replace Products returned to the BOXX facility covered under this limited warranty. To request warranty service, Buyer must call BOXX Technical Support within the warranty period to determine the appropriate actions. In the event that service is required, BOXX Technical Support will issue Buyer a Return Material Authorization Number (RMA). Buyer must ship the Products to BOXX in their original packing. If the original packaging is unavailable, BOXX will supply Buyer with the appropriate shipping container upon request for a nominal fee. In addition to the RMA number and shipping containers, Buyer must prepay shipping charges and insure the shipment with an appropriate shipment carrier or accept the risk of loss or damage during shipment.

WARRANTY INFORMATION

NOTE: IT IS BUYER'S RESPONSIBILITY TO BACK UP THE CONTENTS OF BUYER'S HARD DRIVE BEFORE SERVICES ARE PERFORMED AND TO REMOVE ANY SENSITIVE, CONFIDENTIAL OR OTHER DATA FROM PARTS OR PRODUCTS RETURNED TO BOXX, INCLUDING ANY DATA BUYER HAS STORED OR SOFTWARE BUYER HAS INSTALLED ON THE HARD DRIVE.

It is possible that the contents of the hard drive will be lost or reformatted in the course of service and BOXX will not be responsible for any damage to or loss of any programs, data, or other information stored on any media or any part of any Product serviced. IF DURING THE REPAIR OF THE PRODUCT THE CONTENTS OF THE HARD DRIVE ARE ALTERED, DELETED, OR IN ANY WAY MODIFIED, BOXX IS NOT RESPONSIBLE FOR ANY LOSS OF DATA WHATSOEVER. BUYER'S PRODUCT WILL BE RETURNED CONFIGURED TO THE ORIGINAL FACTORY CONFIGURATION (SUBJECT TO AVAILABILITY OF SOFTWARE). Before shipping Buyer's BOXX Product to BOXX, Buyer should back up all data on the hard-disk drive(s) and storage device(s) used in the Product. In addition, remove any portable media, such as diskettes, CDs, or PC Cards before returning the Product to BOXX. BOXX does not accept liability for lost data or software. Buyer accepts full responsibility for all software and data stored on Products returned to BOXX. BOXX is not required to advise or remind Buyer of appropriate backup procedures. Buyer should note that BOXX uses new and/or reconditioned parts made by various manufacturers in performing warranty repairs and when building replacement Products. In addition, Buyer should also note that BOXX owns all parts removed from replacement or repaired Products. Replacement parts and repaired Products do not extend the Limited Warranty Term described in this Agreement.

BOXX WARRANTY TERMS YEARS TWO AND THREE

During years two and three for APEXX, renderPRO and renderBOXX Products, BOXX offers Buyer parts replacement as described in warranty terms of year one. However, Buyer assumes all shipment and service costs. Buyer should contact its BOXX sales representative for more information.

WARRANTY INFORMATION

BOXX EXCHANGE POLICY

In some instances, BOXX Technical Support may determine that a replacement part will resolve the Product's problem(s) and may opt to ship replacement parts to Buyer. This exchange policy is at the discretion of BOXX and requires Buyer ship the defective part to BOXX before replacement. In these instances, BOXX will provide Buyer with pertinent shipping instructions. As with Product returns and warranty claims, Buyer must ship the part in the original packaging, pay the appropriate shipping charges and insure the shipment with an appropriate shipping carrier or accept the risk of loss or damage during shipment. BOXX will provide an appropriate shipping container upon request for a nominal fee.

Upon arrival, BOXX will verify the defective part and issue Buyer a replacement part within twenty-four hours. The twenty-four hour replacement assumes that BOXX and its suppliers carry the items in inventory and have them available in inventory. If BOXX determines that the part is not defective, BOXX Technical Support will contact Buyer with additional instructions. Buyer should note that BOXX provides replacement parts made by various manufacturers when replacing parts and warranties these parts for the remainder of the applicable Limited Warranty Term.

BOXX EXCHANGES AND ADVANCED REPLACEMENT

BOXX offers Buyer an Advanced Replacement Policy if the BOXX Technical Support staff determines a replacement part will resolve the Product's problem. This policy allows BOXX to ship replacement parts before receiving the defective part from Buyer. BOXX offers this policy to Buyer in good faith to remedy "mission-critical" situations. This Advanced Replacement Policy is at the sole discretion of BOXX and includes BOXX obtaining Buyer's credit information or pre-authorization on Buyer's credit card before shipping the advanced replacement part. If, for any reason, BOXX issues Buyer a replacement part and the defective part does not arrive at BOXX within ten business days, BOXX will hold Buyer financially responsible for the replacement part, shipping charges and other associated sums, including any collection costs expended in efforts to collect such sums.

GENERAL PROVISIONS

This Limited Warranty Agreement is applicable to all Products, regardless of Buyer's location, and may be enforced in any country or region where BOXX or its authorized service providers offer warranty service for the same Product model number subject to the terms and conditions set forth in this 24 Limited Warranty Agreement.

WARRANTY INFORMATION

THIS LIMITED WARRANTY AGREEMENT GIVES BUYER SPECIFIC LEGAL RIGHTS THAT VARY FROM STATE TO STATE (OR JURISDICTION TO JURISDICTION). BOXX'S RESPONSIBILITY FOR MALFUNCTIONS AND DEFECTS IN HARDWARE IS LIMITED TO REPAIR AND REPLACEMENT AS SET FORTH IN THIS AGREEMENT. ALL WARRANTIES FOR THE PRODUCT ARE LIMITED IN DURATION TO THE WARRANTY PERIOD SET FORTH ABOVE AND NO WARRANTIES WILL APPLY AFTER SUCH PERIOD. EXCEPT AS OTHERWISE PROVIDED HEREIN OR UNDER APPLICABLE LAW, ALL PRODUCTS ARE PROVIDED "AS IS" AND WITH ALL FAULTS, AND BOXX HEREBY DISCLAIMS ALL OTHER WARRANTIES AND CONDITIONS, EITHER EXPRESS, IMPLIED, OR STATUTORY, INCLUDING, BUT NOT LIMITED TO, WARRANTIES OF TITLE AND NON-INFRINGEMENT, ANY IMPLIED WARRANTIES, DUTIES OR CONDITIONS OF MERCHANTABILITY, OF FITNESS FOR A PARTICULAR PURPOSE. SOME STATES (OR JURISDICTIONS) DO NOT ALLOW TIME LIMITATIONS ON WARRANTIES. THUS, THE PRECEDING LIMITATION MAY NOT APPLY TO BUYER. HOWEVER, THE ABOVE LIMITATIONS SHALL BE ENFORCED, OR REFORMED IF NECESSARY, TO THE MAXIMUM EXTENT ALLOWED UNDER APPLICABLE LAW.

BOXX DOES NOT ACCEPT LIABILITY BEYOND THE REMEDIES SET FORTH IN THIS AGREEMENT OR LIABILITY FOR INCIDENTAL, SPECIAL, PUNITIVE, INDIRECT OR CONSEQUENTIAL DAMAGES, INCLUDING WITHOUT LIMITATION ANY LIABILITY FOR PRODUCTS NOT BEING AVAILABLE FOR USE, INTERRUPTION OF BUSINESS, INTERRUPTION OF COMMUNICATION SERVICE, FOR LOST DATA, LOST SOFTWARE, LOST PROFITS, OR LOSSES ARISING FROM EVENTS BEYOND BOXX'S CONTROL (SUCH AS ACTS OF GOD, VIRUSES, PROPERTY DAMAGE BY BUYER OR THIRD-PARTY), OR OTHER CONSEQUENTIAL, PUNITIVE OR SPECIAL DAMAGES, HOWSOEVER CAUSED, WHETHER FOR BREACH OF WARRANTY, CONTRACT, TORT (INCLUDING NEGLIGENCE), STRICT LIABILITY OR OTHERWISE, EVEN IF ADVISED OF THE POSSIBILITY OF SUCH DAMAGE. IN ANY CASE, BOXX'S LIABILITY TO BUYER WILL NOT EXCEED THE PRICE BUYER PAID FOR PRODUCT.

SOME STATES (OR JURISDICTIONS) DO NOT ALLOW THE EXCLUSION OR LIMITATION OF INCIDENTAL OR CONSEQUENTIAL DAMAGES, SO THE PRECEDING EXCLUSION OR LIMITATION MAY NOT APPLY TO BUYER. HOWEVER, THE ABOVE LIMITATIONS SHALL BE ENFORCED, OR REFORMED IF NECESSARY, TO THE MAXIMUM EXTENT ALLOWABLE UNDER APPLICABLE LAW. IN ADDITION, IF THE GOVERNING JURISDICTION DOES NOT ALLOW ANY LIMITATIONS OF INCIDENTAL OR CONSEQUENTIAL DAMAGES, BUYER AGREES THAT BOXX'S LIABILITY TO BUYER WILL NOT EXCEED THE PRICE BUYER PAID FOR PRODUCT.

WARRANTY INFORMATION

If any provision contained in this Agreement is for any reason held invalid, illegal or unenforceable in any respect, such invalidity, illegality or unenforceability will not affect any other provision of this Agreement. This Agreement will be construed as if such invalid, illegal or unenforceable provision had never been included, unless the invalidity of any such provision substantially deprives either party of the practical benefits intended to be conferred by this Agreement. Notwithstanding the foregoing, any provision of this Agreement held invalid, illegal or unenforceable only in part or degree will remain in full force and effect to the extent not held invalid or unenforceable, and the determination that any provision of this Agreement is invalid, illegal or unenforceable as applied to particular circumstances will not affect the application of such provision to circumstances other than those as to which it is held invalid, illegal or unenforceable.

Neither BOXX nor its affiliates assume any responsibility for inaccuracies, errors, or omissions that may be contained herein. Neither BOXX nor its affiliates will be held liable for direct, indirect, special, punitive, incidental, or consequential damages resulting from document defects or information omission within this document, even if advised of the possibility of such damages. BOXX reserves the right to make improvements or changes to this document and the Products and services described at any time without notice or obligation.

PREMIUM SUPPORT HARDWARE WARRANTY

BOXX Technologies is proud to offer our Premium Support Services for your recently purchased computer hardware. Our Premium Support level provides you with one year of 24x7 telephone support and Next Business Day Onsite service at no additional charge. Years 2 and 3 of your warranty are the same as the information listed in this manual.

Listed next is a summary of our services. Please distribute this information within your organization to those who need and require warranty services information for your computer hardware.

How to Contact BOXX Technologies Support

Address:  BOXX Technologies
4616 West Howard Lane,
Suite 105
Austin, TX 78728
USA

Phone & Fax:  Phone: 512-835-0400 (press 4)
e-Mail: support@boxx.com
website: www.boxx.com

What to do when you need computer hardware warranty services:

Before calling the BOXX Technologies Help Desk Support Line, listed above, please have the serial number from the failed computer available for our representative. We use this number to verify the terms of coverage, as well as determine the component parts within your computer. Your warranty purchase requires that you allow our Help Desk to perform a minimum amount of troubleshooting / diagnostics to determine the appropriate actions required to resolve the failure, and to identify which spare parts may be required. Often, a field service engineer and parts will be dispatched to perform onsite repairs.

The following details the procedure to follow when you have a service need. If at any time you would like to upgrade your existing plans please feel free to contact us by calling toll free: 1-877-877-BOXX (2699) (press 4) or e-mailing us at sales@boxx.com.

WARRANTY INFORMATION

WHAT TO DO WHEN YOU HAVE A SERVICE ISSUE SERVICE CALL PROCESSING:

- ▶ Contact BOXX Technologies to open a service call

Note: To insure immediate response for 24x7 service requests, call BOXX Technologies at 512.835.0400 (press 4) Support requests sent via e-mail or submitted on-line may only be monitored during normal business hours. The BOXX Technologies' Help Desk is staffed live 24/5 Monday through Friday. Calls taking place 'after hours' will be answered by an answering service and will prompt you to leave a message under "support." One of our after hours help desk technicians will telephone you back within one hour of your call to begin diagnosis.

- ▶ For all Service warranty calls, please be prepared to provide the site name, address, telephone number, the site contact name, the model and serial number(s) of the affected equipment and a brief description of the problem. It is very important that you have the system serial number so our Help Desk can immediately look up your information in our database for quicker and more effective diagnosis of your problem. On-sites can not be scheduled without the serial number of the impacted system.
- ▶ A service call will be logged into our service call system, and a technical service representative will call the site contact within one hour.
- ▶ Our technical service representative will coordinate the dispatch of an on-site service technician as appropriate for your service plan.
- ▶ Your warranty purchase requires that the technician is provided contact information and can access the faulty hardware.
- ▶ Your designated contact will be informed regularly of the progress of open service calls.
- ▶ The BOXX Technologies Help Desk is available 24x7 for assistance in diagnosis of problems with systems that have valid 24x7 onsite service contracts. This does not include support for products that do not include valid 24x7 contracts, or assistance with system administration or software setup / configuration. The Help Desk is available for after-hours assistance in hardware troubleshooting and break / fix resolution only.
- ▶ 24x7 Help Desk does not include assistance with data backup / recovery, RAID configuration, LVM setup or administration, or OS installation.

24x7 SERVICES: 24x7 HELP DESK WITH NEXT BUSINESS DAY (NBD) RESPONSE:

- ▶ Technical help desk support available around the clock, 24 hours /7 days/ week.
- ▶ If call takes place after standard services hours (7PM Friday Evening to 8AM Monday Morning Eastern Time), the call is answered via an automated attendant which electronically notifies one of our 24x7 technical support staff. The call will be returned within one hour (typically 15 minutes).
- ▶ On-site hours of coverage of 8:00am to 5:00 pm customer's site's local time, Monday through Friday – with Next Business Day Response.
- ▶ Due to parts logistics capabilities, the diagnosis must be complete (parts needed identified) by 3pm CST for next business day on-site to take place. If the diagnosis is not complete by 3pm CST, next business day becomes the following business day.
- ▶ Spare / replacement parts must have arrived on-site before BOXX Technologies will dispatch the already acquired and prepared technician.
- ▶ BOXX Technologies will respond to the end-user location as soon as possible and no later than the next business day.

WARRANTY COVERAGE AND LIMITATIONS

THE BOXX TECHNOLOGIES WARRANTY SERVICE PLAN PURCHASED BY YOU DETERMINE THE SERVICES PROVIDED AND THE PERIOD OF WARRANTY COVERAGE. THE WARRANTY SERVICE PLAN PROVIDES FOR THE REPLACEMENT OF SERVER/WORKSTATION COMPONENTS THAT FAIL DUE TO MANUFACTURING DEFECTS IN MATERIALS AND WORKMANSHIP. EXCLUDED FROM WARRANTY COVERAGE ARE ACTS OF NATURE, SUCH AS ELECTRICAL STORMS, FLOODS, FIRE, ETC., ACTS OF WAR AND TERRORISM, CRIMINAL ACTS, AND CUSTOMER DAMAGE AND NEGLIGENCE. UPON RECEIPT OF A SERVICE REQUEST FROM YOU, BOXX TECHNOLOGIES' HELP DESK WILL CONTACT YOU PROMPTLY TO BEGIN DIAGNOSIS AND ARRANGE A TIME FOR THE DELIVERY OF SERVICE. AFTER DIAGNOSIS HAS BEEN PERFORMED, THE HELP DESK WILL THEN COORDINATE THE DISPATCH OF SERVICE PARTS AND FIELD ENGINEERS TO YOUR SITE WITHIN THE TERMS OF YOUR WARRANTY SERVICE PLAN. UNDER THE TERMS OF THE SERVICE PLAN, YOU ARE RESPONSIBLE FOR PROVIDING OUR FIELD SERVICE ENGINEERS WITH ACCESS TO YOUR SERVER/ WORKSTATION IN A SAFE ENVIRONMENT. IF SPARE PARTS HAVE BEEN SHIPPED TO YOU, SHIPPING LABELS WILL HAVE BEEN INCLUDED FOR THE RETURN OF UNUSED AND DEFECTIVE PARTS AFTER SERVICE IS COMPLETE. YOU AGREE TO PROPERLY PACKAGE PARTS FOR RETURN AND DELIVER THE PACKAGE(S) TO THE SELECTED COURIER FOR RETURN TO THE APPROPRIATE ADDRESS ON THE RETURN SHIPPING LABEL. PLEASE CONTACT BOXX TECHNOLOGIES AT 512-835-0400 (PRESS 4) IMMEDIATELY FOR ASSISTANCE WITH PARTS RETURN ISSUES.

©1998-2023 BOXX® TECHNOLOGIES. ALL RIGHTS RESERVED. BOXX®, APEXX®, GOBOXX, RENDERPRO, AND RENDERBOXX® ARE REGISTERED TRADEMARKS OF BOXX TECHNOLOGIES, REGISTERED IN THE U.S. PATENT AND TRADEMARK OFFICE.

NOTES

NOTES

4616 W HOWARD LN SUITE #105
AUSTIN TX 78728
1.877.877.BOXX or 512.835.0400
FAX: 512.835.0434
EMAIL: sales@boxx.com

BOXX

THE PROFESSIONAL'S CHOICE FOR:



WORKSTATIONS



RACKMOUNTS



STORAGE
SOLUTIONS



WORKSTATION
VIRTUALIZATION